

Wheels and castors guide

Fitting types



Plate (top plate)

Bolt hole

Steel plug-in stem

Threaded pin

(product code suffix: -GS...)

The castor is fixed to a level surface using bolts and nuts. The bolt hole spaces are standardised. Plate fittings are available for both swivel and fixed castors and are used for light-duty, transport equipment and heavy-duty castors. The plate must be aligned with the short side facing in the running direction for castors with a directional lock.

The following dimensions must be taken into consideration when selecting the plate fitting:

- plate size (external dimensions)
- bolt hole spaces
- bolt hole \emptyset

Diagrams of top plate fittings with external dimensions and bolt hole spacing: page 106–111

The castor is attached using a connection element (e.g. a bolt) through the central hole of the swivel head. For levelling castors (series HRIG), the bolt hole has a female thread and the connection element is screwed into the central kingpin of the swivel bracket from the unit side.

The load capacities specified here can only be reached if the top plate lies along the entire diameter of the swivel castor.

This fitting type does not provide positive anti-twist locking, and therefore reduces the load capacity of the swivel head brake.

Using a bolt hole to install the castor is a cost-effective solution, which only requires a single bolt (ideally in compliance with DIN 912 / ISO 4762). This fitting type is primarily used for light-duty and transport equipment castors.

The following dimensions must be taken into consideration when selecting the fitting with a bolt hole:

- plate \emptyset (external dimensions) (D)
- bolt hole \emptyset (d)

The castor is fitted using a plug-in stem, which is inserted into a corresponding tube or hole and secured. The stem fitting is fixed to the castor and a fixing bolt (cross hole) or clamp must be used to prevent it rotating or falling out. The hole must be aligned transverse to the running direction for castors with a directional lock.

The load capacities specified here can only be reached if the top plate lies along the entire diameter of the swivel castor.

Stem fittings are primarily used for light-duty, synthetic and transport equipment castors.

A stainless steel plug-in stem fitting is available for stainless steel swivel castors.

The following dimensions must be taken into consideration when selecting the fitting with a stem:

- stem \emptyset (P)
- stem length (Q)
- position of the cross hole (H), if applicable
- diameter of the cross hole (d), if applicable

The castor is fitted using a threaded pin, which is bolted to the transport equipment using a female thread or a cylindrical hole and nut.

Threaded pin fittings are primarily used for light-duty castors.

A stainless steel threaded pin (-GSX...) is available for corrosion-resistant synthetic swivel castors.

The following dimensions must be taken into consideration when selecting the fixing with a threaded pin:

- threaded pin \emptyset (thread M10 or M12) (P)
- threaded pin length (protrusion over the castor) (Q)

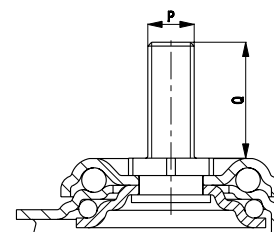
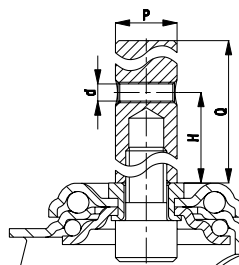
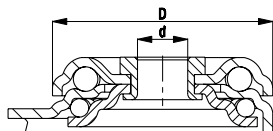
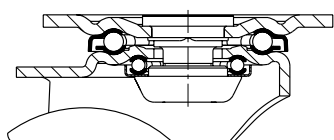

Wheels and castors guide

Fitting types



Plug-in pin

(product code suffix: -ES)

The castor is fitted using a plug-in pin, which is inserted into a corresponding tube or hole using a synthetic castor socket. The pin is firmly connected with the castor. A spring washer ensures that the swivel castor cannot fall out.

Because this fitting type does not provide an anti-twist lock, a swivel head brake will have no effect.

A plug-in pin is a quick and cost-effective method for fitting the castor to the unit. Plug-in pin fittings are primarily used for light-duty castors.

The following dimensions must be taken into consideration when selecting the fitting with a plug-in pin:

- pin \varnothing (P)
- pin length (Q)

Synthetic castor socket for round tubes

(product code: RHR...)

A synthetic castor socket is an adapter that is used to reduce the internal diameter of tubes to the diameter of the plug-in pin. The synthetic castor socket is pressed or driven into the holder on the unit (round tube). A swivel castor with a plug-in pin is then inserted into the castor socket.

The following dimensions must be considered when selecting a synthetic castor socket:

- internal tube \varnothing (P)
- pin \varnothing (d)
- fitting length (Q)
- flange length (B)

Metal expander

(product code suffix: -E...)

The castor is fitted using a metal expander that is inserted into a hole or a square/round tube. The bolt spreads the clamping wedge and presses it against the inner tube wall.

The tightening torque should not exceed 50 Nm. The tightening torque can be reduced to 16 Nm for low-strength thin tubes. A hexagon on the bottom side of the expander prevents the fitting from rotating relative to the castor and coming undone. Metal expander fittings are used for light-duty and synthetic castors.

The following dimensions must be considered when selecting an expander fitting:

- internal tube dimension (P)
- tube shape (round or square tube)
- fitting length (Q)
- flange length (B)

See page 148, 168 and 180 for information about options

Synthetic expander

(product code suffix: -ER.../ -EV...)

The castor is fitted using a synthetic expander, which is inserted into a hole or a square/round tube. The bolt presses the synthetic clamping wedge against the inner tube wall.

A synthetic expander provides greater protection for the inside of the tube compared to metal expander fittings. However, it provides less holding force than a metal expander fitting. A hexagon on the bottom side of the expander prevents the fitting from rotating relative to the castor and coming undone. Synthetic expander fittings are mainly used for light-duty and synthetic castors.

A synthetic expander with a corrosion-resistant clamping screw (-EXR.../ -EXV...) is also available.

The following dimensions must be considered when selecting an expander fitting:

- internal tube dimension (P)
- tube shape (round or square tube)
- fitting length (Q)
- flange length (B)

See page 148, 168, 180 and 398 for information about options

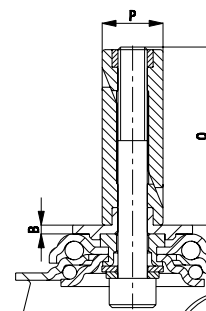
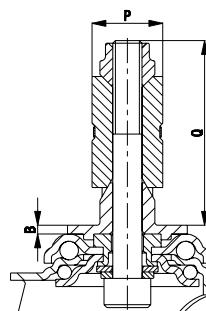
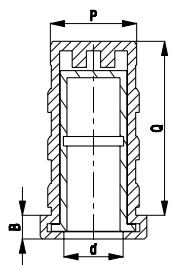
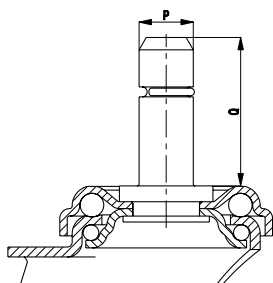

Wheels and castors guide

Fitting types plate fitting

Top plate fittings for light-duty and synthetic castors

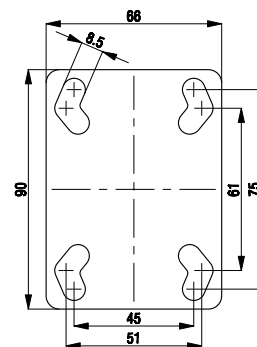
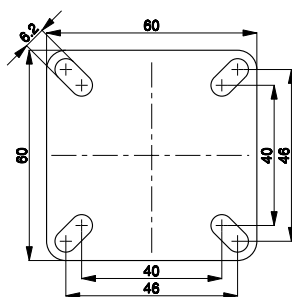
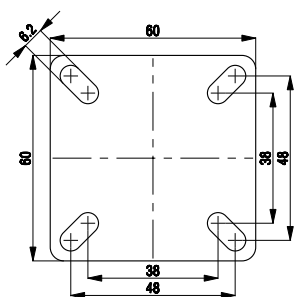
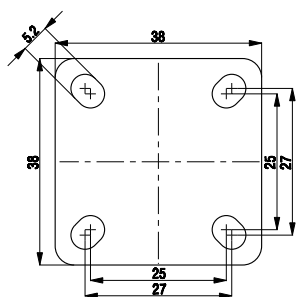

Plate no. 20

Plate no. 22

Plate no. 23

Plate no. 25 (swivel castor)

use in bracket series:

LKDB wheel Ø 50–75 mm

use in bracket series:

LPA / BPA wheel Ø 35–100 mm

LPXA / BPXA wheel Ø 50–75 mm

LDA wheel Ø 50 mm

use in bracket series:

LDA wheel Ø 75 mm

LKDG / LKDB wheel Ø 75–100 mm

use in bracket series:

LKPA wheel Ø 80–150 mm

LKPXA wheel Ø 80–125 mm

LWK / LWG-P25 wheel Ø 100–125 mm

LWKX / LWGX-PX25 wheel Ø 100–125 mm

LKFG / BKFG wheel Ø 125 mm

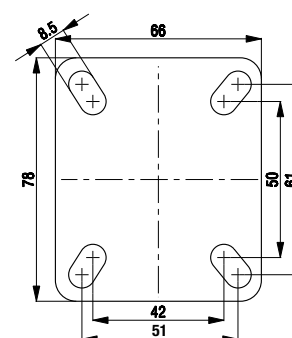
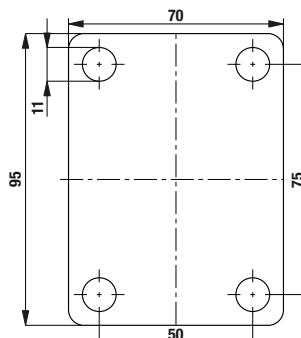
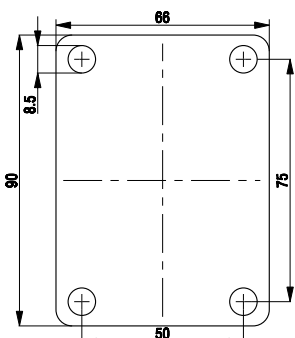
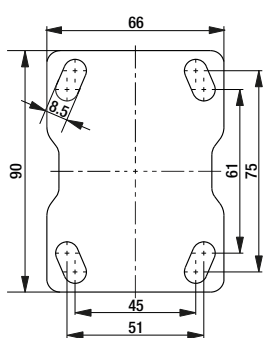

Plate no. 25 (fixed castor)

Plate no. 26

Plate no. 27

Plate no. 28

use in bracket series:

BKPA wheel Ø 80–150 mm

BKPXA wheel Ø 80–125 mm

use in bracket series:

LKPXA / BKPXA wheel Ø 125 mm

LWKX / LWGX-PX26 wheel Ø 125 mm

use in bracket series:

LKFGX / BKFGX wheel Ø 125 mm

use in bracket series:

LWK / LWG-P28 wheel Ø 100–125 mm

Wheels and castors guide

Fitting types plate fitting

Top plate fittings for transport equipment and heavy-duty castors

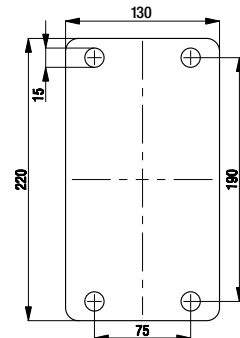
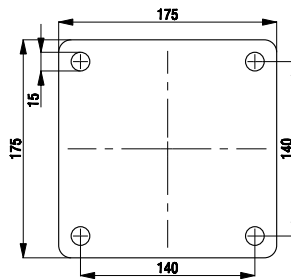
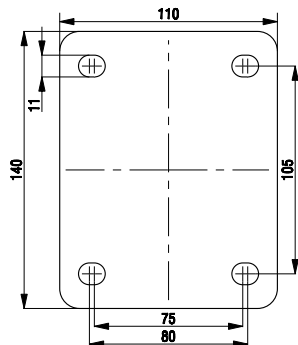
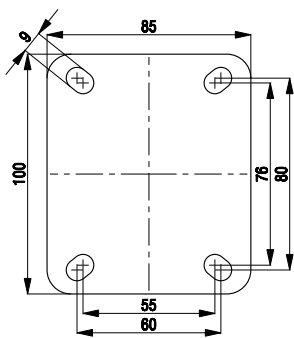

Plate no. 1

Plate no. 3

Plate no. 7

Plate no. 9

use in bracket series:

LE / B	wheel Ø	60–125 mm
LEX / BX	wheel Ø	75–200 mm
L / B	wheel Ø	75–125 mm
LX / BX	wheel Ø	100–125 mm
LI / B	wheel Ø	80–125 mm
LIX / BX	wheel Ø	80–125 mm
LK / BK	wheel Ø	75–125 mm
LKX / BKX	wheel Ø	75–125 mm
LIK / BIK	wheel Ø	100–125 mm
LIKX / BKX	wheel Ø	100–125 mm
LH / BH	wheel Ø	75–125 mm
LHD	wheel Ø	60–80 mm
LHF / BHF	wheel Ø	100–125 mm
LPFE / BPFE	wheel Ø	100–125 mm
HRLH / HRLHD	wheel Ø	75 mm
HRLK	wheel Ø	75–100 mm

use in bracket series:

LE / B	wheel Ø	150–200 mm
LEX / BX	wheel Ø	150–200 mm
L / B	wheel Ø	140–250 mm
LX / BX	wheel Ø	150–200 mm
LI / BI	wheel Ø	150–200 mm
LIX / BX	wheel Ø	150–200 mm
LK / BK	wheel Ø	100–200 mm
LKX / BKX	wheel Ø	125–200 mm
LU / BH	wheel Ø	125–200 mm
LH / BH	wheel Ø	100–250 mm
LHD	wheel Ø	80–125 mm
LO / BO	wheel Ø	125–300 mm
LOD / BOD	wheel Ø	75–125 mm
LS / BS	wheel Ø	100–200 mm
LSD / BSD	wheel Ø	80–125 mm
LHF / BHF	wheel Ø	100–200 mm
LPFE / BPFE	wheel Ø	125–150 mm
LSFN / BSFN	wheel Ø	160–200 mm
LSFE / BSFE	wheel Ø	160–200 mm
LIO / BO	wheel Ø	125–250 mm

use in bracket series:

L	wheel Ø	250–280 mm
---	---------	------------

use in bracket series:

B	wheel Ø	250–280 mm
---	---------	------------

Wheels and castors guide

Fitting types plate fitting

Top plate fittings for heavy-duty castors

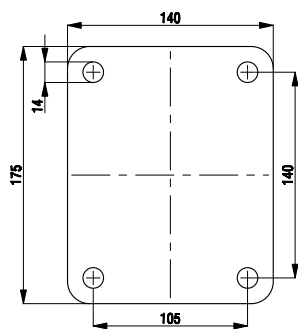

Plate no. 35

use in bracket series:

LS / BS	wheel Ø	150–400 mm
LSD / BSD	wheel Ø	100–200 mm
LSFN / BSFN	wheel Ø	200–250 mm
LSFE / BSFE	wheel Ø	200–250 mm
HRLSD	wheel Ø	125 mm

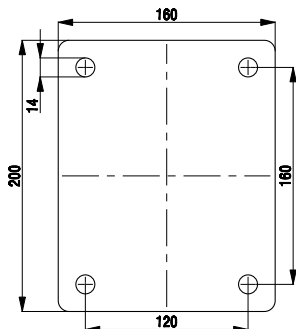

Plate no. 36

use in bracket series:

LS / BS	wheel Ø	300–520 mm
LSFN / BSFN	wheel Ø	250–300 mm
LSFE / BSFE	wheel Ø	250 mm

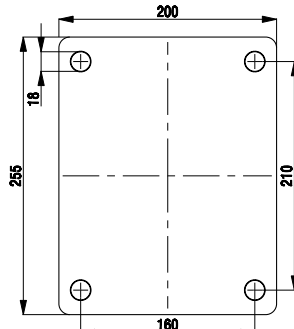

Plate no. 38

use in bracket series:

LS / BS	wheel Ø	200–620 mm
LSD / BSD	wheel Ø	125–360 mm

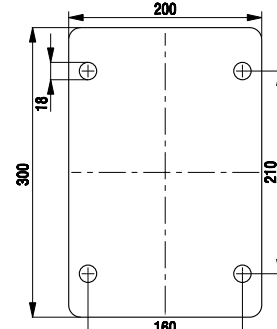

Plate no. 39

use in bracket series:

BSD	wheel Ø	300 mm
-----	---------	--------

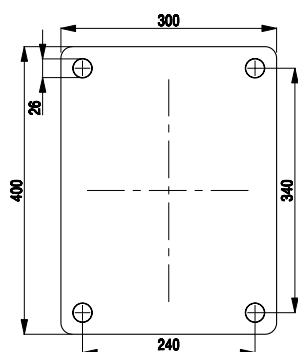

Plate no. 42

use in bracket series:

LS / BS	250–600 mm
LSD / BSD	250–500 mm

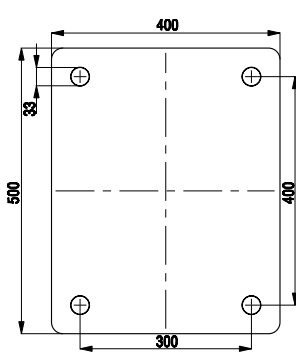

Plate no. 45

use in bracket series:

LSD / BSD	wheel Ø	300–400 mm
-----------	---------	------------

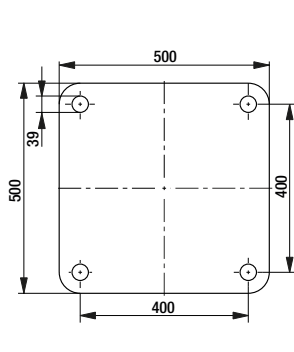

Plate no. 48

use in bracket series:

LSSD / BSSD	wheel Ø	500 mm
-------------	---------	--------

Wheels and castors guide

Fitting types plate fitting

Top plate fittings for levelling castors

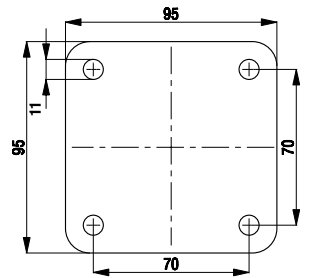
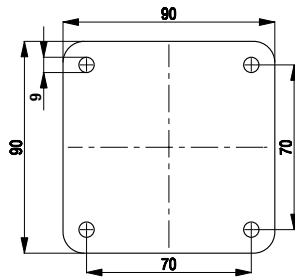
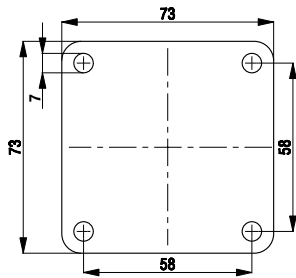
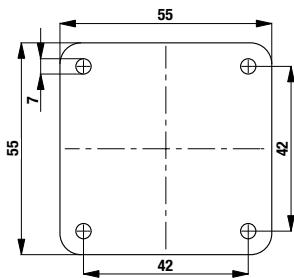

Plate no. 71

Plate no. 72

Plate no. 74

Plate no. 76

use in bracket series:
HRP wheel Ø 45 mm

use in bracket series:
HRP wheel Ø 50 mm

use in bracket series:
HRP wheel Ø 63 mm

use in bracket series:
HRP wheel Ø 72 mm
HRSP wheel Ø 72 mm

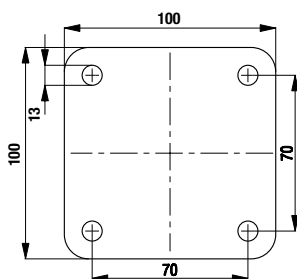

Plate no. 78

use in bracket series:
HRSP wheel Ø 90 mm

Wheels and castors guide

Fitting types plate fitting

Top plate fittings with imperial dimensions (inches)

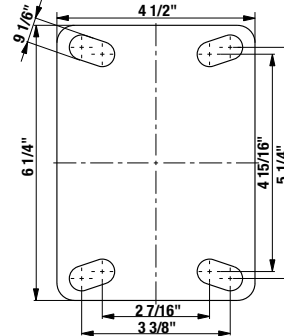
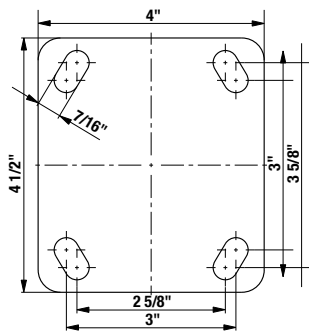
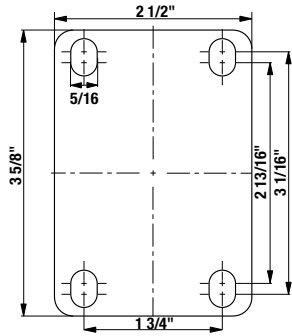

Plate no. 12

Plate no. 14

Plate no. 16

top plate fittings with non-metric dimensions (inches)
in accordance with ASME B56.11.1
(see Blickle "American Standard Casters" catalogue)

top plate fittings with non-metric dimensions (inches)
in accordance with ASME B56.11.1
(see Blickle "American Standard Casters" catalogue)

top plate fittings with non-metric dimensions (inches)
in accordance with ASME B56.11.1
(see Blickle "American Standard Casters" catalogue)

Wheels and castors guide

Fitting types plate fitting

Top plate fittings for Progressus castors

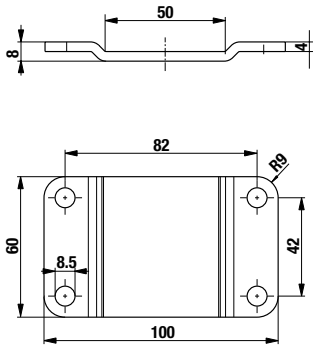

Plate no. PG1

use in bracket series:
LPX / BPX wheel Ø 84–105 mm

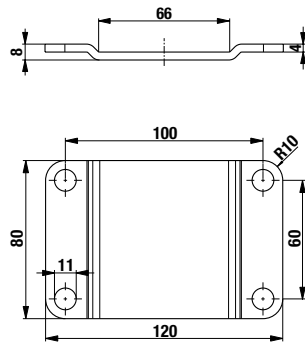

Plate no. PG2

use in bracket series:
LPX / BPX wheel Ø 120–150 mm

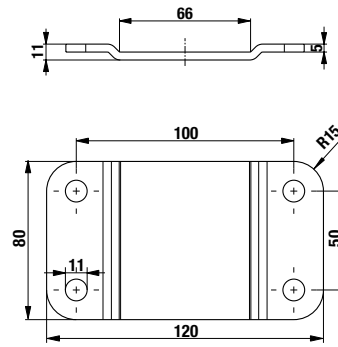

Plate no. PG3

use in bracket series:
LPX / BPX wheel Ø 186 mm